

# WINCO®

**DR2014-  
DR130F4  
GENERATORS**

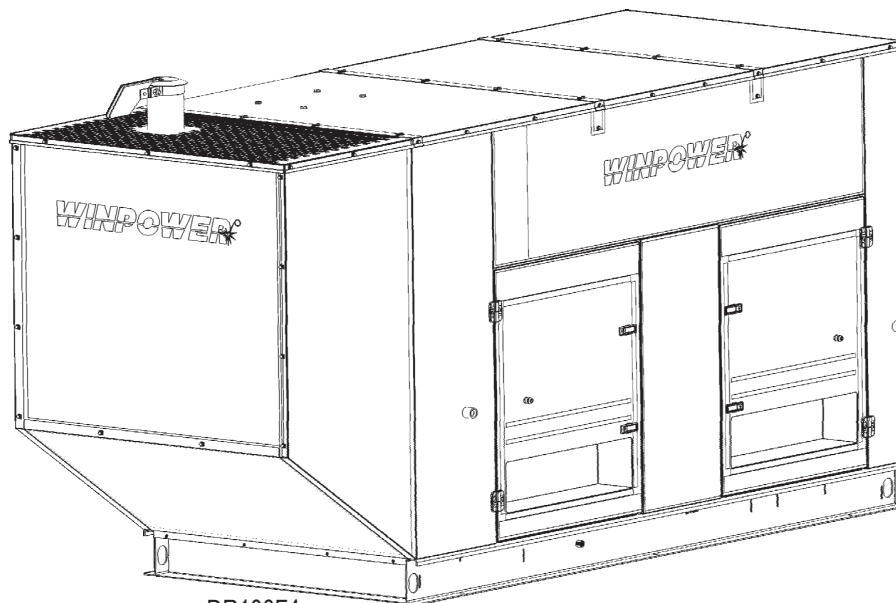

DR100F4

# INSTALLATION AND OPERATORS MANUAL

**DSE 7310 MKII ELECTRIC START**

WINCO INC. 225 S. CORDOVA AVE. LE CENTER, MN 56057  
SERVICE DEPT. 507-357-6831 • SALES DEPT. 507-357-6821

[www.wincogen.com](http://www.wincogen.com)

# TABLE OF CONTENTS

## SAVE THESE INSTRUCTIONS

### SAFETY INFORMATION

ANSI SAFETY DEFINITIONS

### TESTING POLICY

### SPECIFICATIONS

DR2014  
DR3014  
DR45F4  
DR65F4  
DR90F4  
DR100F4  
DR130F4

### INTRODUCTION

PRODUCT DESCRIPTION

### PREPARING THE UNIT

UNPACKING  
LIFTING THE GENERATOR SET

### INSTALLATION

GENERAL INFORMATION  
ENGINE GENERATOR SET MOUNTING  
INSTALLING THE FUEL LINE  
INSTALLING THE BATTERY  
CONNECTING BATTERY CHARGER & BLOCK HEATER  
MOUNTING THE AUTOMATIC TRANSFER SWITCH

### A.C. ELECTRICAL CONNECTIONS

### D.C. ELECTRICAL CONNECTIONS

GROUNDING  
DC INTERCONNECTIONS TO THE ATS

### STARTING PROCEDURE

INITIAL START UP

### MAINTENANCE SCHEDULE

### TROUBLESHOOTING TABLE

### VOLTAGE REGULATOR WIRING

### WIRING SIZE TABLE

### ENGINE HARNESS SCHEMATIC

DR20  
DR45/DR65

### DSE 7310 MKII WIRING DIAGRAM

### THREE PHASE WIRING - DELTA

### THREE PHASE AC WIRE HIGH AND LOW WYE

### SINGLE PHASE AC WIRING - 4 LEAD

### 12 MONTH LIMITED WARRANTY

COPY YOUR MODEL AND SERIAL NUMBER HERE

No other WINCO generator has the same serial number as yours.

If you should ever need to contact us on this unit, it will help us to respond to your needs faster.

**2**

**3** MODEL \_\_\_\_\_

**3** SERIAL NUMBER \_\_\_\_\_

**4** PURCHASE DATE \_\_\_\_\_

DEALER NAME \_\_\_\_\_

DEALER PHONE # \_\_\_\_\_

## 7 SAVE THESE INSTRUCTIONS

**8** This manual contains important instructions that should be followed during installation and maintenance of the generator. Read and understand all instructions in the manual before starting and operating the generator.

**9** USING THIS MANUAL  
Congratulations on your choice of a WINCO generator. You have selected a high-quality, precision-engineered generator designed and tested to give you years of satisfactory service.

To get the best performance from your new generator, it is important that you carefully read and follow the operating instructions in this manual.

**11**

**12** Should you experience a problem please follow the "Troubleshooting Tables" near the end of this manual. The warranty listed in the manual describes what you can expect from WINCO should you need service assistance in the future.

**13**

**15**

**15**

**16**

**16**

**17**

**18**

**19**

**19**

**19**

**20**

# SAFETY INFORMATION

This engine generator set has been designed and manufactured to allow safe, reliable performance. Poor maintenance, improper or careless use can result in potentially deadly hazards; from electrical shock, exhaust gas asphyxiation, or fire. Please read all safety instructions carefully before installation or use. Keep these instructions handy for future reference. Take special note and follow all warnings on the unit labels and in the manuals.

## ANSI SAFETY DEFINITIONS

### DANGER:

*DANGER indicates an imminently hazardous situation which, if not avoided, will result in death or serious injury. This signal word is to be limited to the most extreme situations.*

### WARNING:

*WARNING indicates a potentially hazardous situation which, if not avoided, could result in death or serious injury.*

### CAUTION:

*CAUTION indicates a potentially hazardous situation which, if not avoided, may result in minor or moderate injury. It may also be used to alert against unsafe practices.*

#### 1. ELECTRICAL SHOCK -

The output voltage present in this equipment can cause fatal electric shock. This equipment must be operated by a responsible person.

- A. Do not allow anyone to operate the generator without proper instruction.
- B. Guard against electric shock.
- C. Avoid contact with live terminals or receptacles.
- D. Use extreme care if operating this unit in rain or snow.
- E. Use only three-pronged grounded receptacles and extension cords.
- F. Be sure the unit is properly grounded to an external ground rod driven into the earth.

#### 2. FIRE HAZARD -

Gasoline and other fuels present a hazard of possible explosion and/or fire.

- A. Do not refuel when the engine is running or hot.
- B. Keep fuel containers out of reach of children.
- C. Do not smoke or use open flame near the generator set or fuel tank.
- D. Keep a fire extinguisher nearby and know its proper use. Fire extinguishers rated ABC by NFPA are appropriate.
- E. Store fuel only in an approved container, and only in a well ventilated area.
- F. Follow local codes for closeness to combustible material.

#### 3. DEADLY EXHAUST GAS -

Exhaust fumes from any gasoline engine contain carbon monoxide, an invisible, odorless and deadly gas that must be mixed with fresh air.

- A. Operate only in well ventilated areas.
- B. Never operate indoors including attached garages
- C. Never operate the unit in such a way as to allow exhaust gases to seep back into closed rooms (i.e. through windows, walls, floors).

#### 4. NOISE HAZARD -

Excessive noise is not only tiring, but continual exposure can lead to loss of hearing.

- A. Use hearing protection when working around this equipment for long periods of time.
- B. Keep your neighbors in mind when using this equipment.

#### 5. CLEANLINESS -

Keep the generator and surrounding area clean.

- A. Remove all grease, ice, snow or materials that create slippery conditions around the unit.
- B. Remove any rags or other materials that could create a potential fire hazard.
- C. Carefully clean up any gas or oil spills before starting the unit.

#### 6. SERVICING EQUIPMENT -

All service, including the installation or replacement of service parts, should be performed only by a qualified technician.

- A. Use only factory approved repair parts.
- B. Do not work on this equipment when fatigued.
- C. Never remove the protective guards, covers, or receptacle panels while the engine is running.
- D. Use extreme caution when working on electrical components. High output voltage from this equipment can cause serious injury or death.
- E. Always avoid hot mufflers, exhaust manifolds, and engine parts. They can cause severe burns instantly.
- F. The use of the engine-generator set must comply with all national, state, and local codes.

## TESTING POLICY

Before any generator is shipped from the factory, it is fully checked for performance. The generator is loaded to its full capacity, and the voltage, current, and frequency are carefully checked.

Rated output of generator is based on engineering tests of typical units, and is subject to, and limited by, the temperature, altitude, fuel, and other conditions specified by the manufacturer of applicable engines.

This unit comes factory set for either key start or manual start. With the DSE 7310 MKII controller used in the manual start option it is possible to wire the control for remote start. Wiring instructions can be found further in this manual. The key start version does not have this option.

# SPECIFICATIONS

## DR2014

Generator				
Wattage	20,000	20,000	20,000	20,000
Volts	120/240	120/208	120/240	277/480
Phase	Single	Three	Three	Three
PF	1.0	.80	.80	.80
Amps	83	69	60	30
CB Size	90	75	60	30
Hertz	60	60	60	60
Engine				
Model	Isuzu 4LE1 2.2L			
Starting System	12 Volt			
Muffler	Standard			
Fuel Consumption (full load)	1.8 Gal/Hr			

### Generator Testing Resistance

Note: Review the Stamford Newage nameplate on your generator before selecting the correct information below.

Model	Stamford PI144D1J
Winding Group	311
Resistances:	
Rotor	0.657 Ohms @22°C
Stator	0.377 Ohms Per Ph @ 22°C
Exciter Rotor	0.228 Ohms Per Ph @ 22°C
Exciter Stator	18.5 Ohms @ 22°C
Voltage Regulator	AS480

Model	Stamford PI1144D
Winding Group	06
Resistances:	
Rotor	0.657 Ohms @22°C
Stator	0.377 Ohms Per Ph @ 22°C
Exciter Rotor	0.228 Ohms Per Ph @ 22°C
Exciter Stator	18.5 Ohms @ 22°C
Voltage Regulator	AS480

### Engine Fluid Specifications

Fuel	ASTM D-975 -1D or 2D EN590 or equivalent
Oil Type	SEE LUBRICATION SECTION
Oil Capacity	8.8 Quarts
Cooling System	50/50 mix

## DR3014

Generator				
Wattage	29,000	30,000	30,000	30,000
Volts	120/240	120/208	120/240	277/480
Phase	Single	Three	Three	Three
PF	1.0	.80	.80	.80
Amps	120	104	90	45
CB Size	125	100	90	45
Hertz	60	60	60	60
Engine				
Model	Isuzu 4LE1 2.2L			
Starting System	12 Volt			
Muffler	Standard			
Fuel Consumption (full load)	3.13 Gal/Hr			

### Generator Testing Resistance

Note: Review the Stamford Newage nameplate on your generator before selecting the correct information below.

Model	Stamford PI144H
Winding Group	311
Resistances:	
Rotor	0.89 Ohms @22°C
Stator	0.179 Ohms Per Ph @ 22°C
Exciter Rotor	0.21 Ohms Per Ph @ 22°C
Exciter Stator	22.9 Ohms @ 22°C
Voltage Regulator	AR480

Model	Stamford PI1144D
Winding Group	06
Resistances:	
Rotor	0.857 Ohms @22°C
Stator	0.073 Ohms Per Ph @ 22°C
Exciter Rotor	0.201 Ohms Per Ph @ 22°C
Exciter Stator	20.3 Ohms @ 22°C
Voltage Regulator	AS480

### Engine Fluid Specifications

Fuel	ASTM D-975 -1D or 2D EN590 or equivalent
Oil Type	SEE LUBRICATION SECTION
Oil Capacity	8.5 Quarts
Cooling System	50/50 mix

## DR45F4

Generator				
Wattage	45,000	45,000	45,000	45,000
Volts	120/240	120/208	120/240	277/480
Phase	Single	Three	Three	Three
PF	1.0	.80	.80	.80
Amps	187	156	135	68
CB Size	175	150	125	70
Hertz	60	60	60	60
Engine				
Model	FPT N45 SM1 4.5L			
Starting System	12 Volt			
Muffler	Standard			
Fuel Consumption (full load)	4.09 Gal/Hr			

### Generator Testing Resistance

Note: Review the Stamford Newage nameplate on your generator before selecting the correct information below.

Model	Stamford UCI224D
Winding Group	311
Resistances:	
Rotor	0.64 Ohms @22°C
Stator	0.065 Ohms Per Ph @ 22°C
Exciter Rotor	0.142 Ohms Per Ph @ 22°C
Exciter Stator	21.0 Ohms @ 22°C
Voltage Regulator	SX460

Model	Stamford UCI224E
Winding Group	06
Resistances:	
Rotor	0.69 Ohms @22°C
Stator	0.02 Ohms Per Ph @ 22°C
Exciter Rotor	0.156 Ohms Per Ph @ 22°C
Exciter Stator	20.0 Ohms @ 22°C
Voltage Regulator	SX460

### Engine Fluid Specifications

Fuel	ASTM D-975 -1D or 2D EN590 or equivalent
Oil Type	SEE LUBRICATION SECTION
Oil Capacity	13.5 Quarts
Cooling System	50/50 mix

## DR65F4

Generator				
Wattage	62,000	62,000	62,000	62,000
Volts	120/240	120/208	120/240	277/480
Phase	Single	Three	Three	Three
PF	1.0	.80	.80	.80
Amps	258	215	186	93
CB Size	250	225	175	100
Hertz	60	60	60	60
Engine				
Model	FPT N45 SM2 4.5L			
Starting System	12 Volt			
Muffler	Standard			
Fuel Consumption (full load)	4.57 Gal/Hr			

### Generator Testing Resistance

Note: Review the Stamford Newage nameplate on your generator before selecting the correct information below.

Model	Stamford UCI224F
Winding Group	311
Resistances:	
Rotor	0.83 Ohms @22°C
Stator	0.033 Ohms Per Ph @ 22°C
Exciter Rotor	0.156 Ohms Per Ph @ 22°C
Exciter Stator	20.0 Ohms @ 22°C
Voltage Regulator	SX460

Model	Stamford UCI224G
Winding Group	06
Resistances:	
Rotor	0.94 Ohms @22°C
Stator	0.1 Ohms Per Ph @ 22°C
Exciter Rotor	0.156 Ohms Per Ph @ 22°C
Exciter Stator	20.0 Ohms @ 22°C
Voltage Regulator	SX460

### Engine Fluid Specifications

Fuel	ASTM D-975 -1D or 2D EN590 or equivalent
Oil Type	SEE LUBRICATION SECTION
Oil Capacity	13.5 Quarts
Cooling System	50/50 mix

## DR90F4

Generator				
Wattage	86,000	90,000	90,000	90,000
Volts	120/240	120/208	120/240	277/480
Phase	Single	Three	Three	Three
PF	1.0	.80	.80	.80
Amps	358	312	271	135
CB Size	350	300	250	125
Hertz	60	60	60	60
Engine				
Model	FPT N45 TM2 4.5L			
Starting System	12 Volt			
Muffler	Standard			
Fuel Consumption (full load)	6.94 Gal/Hr			

### Generator Testing Resistance

Note: Review the Stamford Newage nameplate on your generator before selecting the correct information below.

Model	Stamford UCI274C
Winding Group	311
Resistances:	
Rotor	1.19 Ohms @22°C
Stator	0.0045 Ohms Per Ph @ 22°C
Exciter Rotor	0.136 Ohms Per Ph @ 22°C
Exciter Stator	18.0 Ohms @ 22°C
Voltage Regulator	SX460

Model	Stamford UCI274C
Winding Group	06
Resistances:	
Rotor	1.37 Ohms @22°C
Stator	0.0037 Ohms Per Ph @ 22°C
Exciter Rotor	0.136 Ohms Per Ph @ 22°C
Exciter Stator	18.0 Ohms @ 22°C
Voltage Regulator	SX460

### Engine Fluid Specifications

Fuel	ASTM D-975 -1D or 2D EN590 or equivalent
Oil Type	SEE LUBRICATION SECTION
Oil Capacity	13.5 Quarts
Cooling System	50/50 mix

## DR100F4

Generator				
Wattage	100,000	105,000	105,000	115,000
Volts	120/240	120/208	120/240	277/480
Phase	Single	Three	Three	Three
PF	1.0	.80	.80	.80
Amps	416	364	315	172
CB Size	400	350	300	175
Hertz	60	60	60	60
Engine				
Model	FPT N67 TM1 6.7L			
Starting System	12 Volt			
Muffler	Standard			
Fuel Consumption (full load)	7.71 Gal/Hr			

### Generator Testing Resistance

Note: Review the Stamford Newage nameplate on your generator before selecting the correct information below.

Model	Stamford UCI274D
Winding Group	311
Resistances:	
Rotor	1.19 Ohms @22°C
Stator	0.0045 Ohms Per Ph @ 22°C
Exciter Rotor	0.136 Ohms Per Ph @ 22°C
Exciter Stator	18.0 Ohms @ 22°C
Voltage Regulator	SX460

Model	Stamford UCI274D
Winding Group	06
Resistances:	
Rotor	1.37 Ohms @22°C
Stator	0.0037 Ohms Per Ph @ 22°C
Exciter Rotor	0.136 Ohms Per Ph @ 22°C
Exciter Stator	18.0 Ohms @ 22°C
Voltage Regulator	SX460

### Engine Fluid Specifications

Fuel	ASTM D-975 -1D or 2D EN590 or equivalent
Oil Type	SEE LUBRICATION SECTION
Oil Capacity	18 Quarts
Cooling System	50/50 mix

# DR130F4

Generator				
Wattage	123,000	130,000	130,000	130,000
Volts	120/240	120/208	120/240	277/480
Phase	Single	Three	Three	Three
PF	1.0	.80	.80	.80
Amps	512	451	391	195
CB Size	500	450	400	200
Hertz	60	60	60	60
Engine				
Model	FPT N67 TM1 6.7L			
Starting System	12 Volt			
Muffler	Standard			
Fuel Consumption (full load)	8.8 Gal/Hr			

## Generator Testing Resistance

Note: Review the Stamford Newage nameplate on your generator before selecting the correct information below.

Model	Stamford UCI274F
Winding Group	311
Resistances:	
Rotor	1.19 Ohms @22°C
Stator	0.0045 Ohms Per Ph @ 22°C
Exciter Rotor	0.136 Ohms Per Ph @ 22°C
Exciter Stator	18.0 Ohms @ 22°C
Voltage Regulator	SX460

Model	Stamford UCI274F
Winding Group	06
Resistances:	
Rotor	1.37 Ohms @22°C
Stator	0.0037 Ohms Per Ph @ 22°C
Exciter Rotor	0.136 Ohms Per Ph @ 22°C
Exciter Stator	18.0 Ohms @ 22°C
Voltage Regulator	SX460

## Engine Fluid Specifications

Fuel	ASTM D-975 -1D or 2D EN590 or equivalent
Oil Type	SEE LUBRICATION SECTION
Oil Capacity	18 Quarts
Cooling System	50/50 mix

# INTRODUCTION

## PRODUCT DESCRIPTION

This engine-generator set is designed for unattended remote start operation. It can be operated as part of a fully automatic standby power system or independently as a local start unit in a prime power system. The engine-generator set is fully tested at the factory prior to shipment to insure proper operation of each individual component as well as the total system's performance and reliability.

The engine generator set consists of a multi-cylinder, liquid cooled engine nominally operating at 1800 rpm. The generator frequency regulation is maintained by the engine governor to within +/- 1.5 Hz (cps), from no load to rated load for standard mechanical governors and to within +/- .5 Hz or better for units equipped with an electronic governor. The generator is a single bearing, direct drive, rotating field design. The generator is connected to the engine flywheel via flexible drive disks. Generator set is skid mounted with isolation mounts between the engine and base on all units.

A customer supplied 12 Volt battery is required to complete the installation. Battery requirements are listed later under the battery installation section.

**Unit Orientation Note:** All references used in this manual for unit familiarization, access and component locations on the Generator Set are oriented from a TOP (plan) VIEW with engine at the FRONT and generator to the REAR.

WINPOWER uses a common junction box for all customer control and power connections (both AC output and DC control). The common electrical junction box is always on the left side at the generator end of the machine.

The engine is controlled and Generator Set operation is monitored for safe operation by a programmable microprocessor based electronic Engine Control Module (ECM) with an LCD digital display. The generator set ECM control is mounted on a vertical pedestal on the right side of the generator. The ECM is programmed with a cycle cranking sequence - 3 cycles of 15 seconds on/15 seconds off, and 5 minute cool-down delay. The cool-down delay can be changed in the field from 0 to 30 minutes by your installer. Other features, timing cycles, set points, and signal output capabilities are possible. Consult factory for procedure and passwords.

### NOTICE:

*These units will automatically transfer if a power outage occurs while running in exercise mode.*

## GENERATOR SET

Every WINCO generator set has its own unique identity data plate. This data plate identifies the complete unit model number, the system serial number, and has links to the individual components that form the generator set in our factory records. Several of the major components also have their own individual data plates providing additional information to document build data for warranty and replacement parts.

## ENGINE

Refer to the engine operators manual for more detailed operation and maintenance information.

### CAUTION: EQUIPMENT DAMAGE:

*Be sure to check the engine oil level frequently as specified in the engine manual.*

The engine manufacturer has established an excellent worldwide engine service organization; engine service is available from a nearby authorized dealer or distributor. Go to the WINCO website for a list of engine dealers ([http://wincogen.com/Engine\\_Support](http://wincogen.com/Engine_Support)) or contact the WINCO Service Department.

The rated power of each engine-generator is limited by the temperature, altitude, and all other ambient conditions specified by the engine manufacturer. Engine power may decrease 3½% for each 1000 feet above sea level, and will decrease an additional 1% for each 10 degrees Fahrenheit above 60° Fahrenheit. Units should not be operated in ambient temperature greater than 125° Fahrenheit.

## GENERATOR

WINCO generator sets use brushless, AVR (Auto-Voltage Regulator) controlled broad-range generator ends. The generator converts rotational mechanical energy into electrical energy. These WINCO units are equipped with generators manufactured by Cummins Generator Technology. Each generator 'end' has its own data tag. A unique serial number is on the data plate.

### MODEL NUMBER STRUCTURE

The WINPOWER alpha-numerical numbering consists of a base model designation, followed by an options section, separated by a dash mark. The base component of the model numbering system identifies an engine type, engine starting method, fuel type, kilowatt rating, engine manufacturer, and number of generator poles. Following the separation dash mark is the voltage connection and optional installed equipment. Options include features like, weather enclosures (housing), base mounted fuel tank sizes, and trailer options.

Please note that some features or packages, such as NFPA level I & II, do not have an indication place in this numbering system. They are issued and built with an M-Spec (i.e. M-10372) number which can be found on the WINPOWER data tag. When the M-Spec is present, supplemental inserts will accompany this standard manual providing information about the special equipment and features installed. The standard model numbering key that can be used along with the data tag information and/or M-Spec supplements to determine the generator set's ratings and specifications.

<b>D</b>	D = Diesel
<b>R</b>	R = Remote Start
<b>30</b>	Generator Output Rating in kW
<b>I</b>	Engine Manufacturer: I = Isuzu; F = FPT
<b>4</b>	Number of Generator Poles
<b>-</b>	Base Unit - Options Separator
<b>A</b>	Voltage A (3) = Single Phase 120/240V D (4) = Three Phase 120/208V J (17) = Three Phase 120/240V L (18) = Three Phase 277/480V
<b>A</b>	HOUSING TYPE A = Sound Attenuated/Weather Protective * = No Housing
<b>M</b>	Fuel Tank Size: S = Small; M = Medium; L = Large; P = Plastic; * = None
<b>T</b>	T = Trailer; * = None
<b>D</b>	Battery Charger Options A = 12V/.75A; B = 12V/3.5A; C = 12V/6A; D = 12V/10A; E = 12V/6A NFPA; F = 12V/10A NFPA; G = 24V/3.5A; H = 24V/10A; I = 24V/10A NFPA; J = 12V/2A; K = 12VDC/5A DSE; L = 24VDC/10A DSE

## PREPARING THE UNIT

### UNPACKING

1. As you receive your unit, it is critical to check it for any damage. If any damage is noted, it is always easiest to refuse the shipment and let WINCO take care of the freight claim. If you sign for the unit, the transfer of the ownership requires that you file the freight claim
2. Before proceeding with the preparations of your new generator for operation, take a couple of minutes to ensure the unit you have received is the correct model and review the specification pages in this manual to ensure that this unit meets your job requirements.

### CAUTION: EQUIPMENT DAMAGE:

*This unit is shipped with oil and a 50/50 mix of coolant. Be sure to check all fluid levels before operating. See engine manufacturer's instruction manual for recommended oil requirements before initial starting.*

### Once generator set is on-site:

1. Carefully remove the crate.
2. After inspecting the engine-generator for external, physical damage, locate and check the following items packed with the unit:
  - a. Installation and Operator's Manual.
  - b. Engine manufacturer's instruction manual.
  - c. Battery hold-down brackets & hardware.
  - d. Unit components or accessory items shipped loose for on-site installation.
  - e. Optional accessories.
3. Remove main frame hold-down bolts.
4. Unit can now be lifted from shipping rails.



## LIFTING THE GENERATOR SET

### NOTICE: PERSONAL INJURY:

*To prevent injury to persons or equipment, observe the following guidelines when lifting the generator:*

Due to the different designs, configurations, options, weights, site conditions, and available material handling equipment, specific lifting instructions are not provided for each individual generator set model. General guidelines provided are applicable to the entire generator line. It is the responsibility of the installing party to follow the lifting equipment's operator's manual to prevent injury to personnel and damage to the generator. Smaller generator sets may not require use of overhead lifting equipment and may be placed on the pad with basic material handling equipment, i.e. a forklift.

### CAUTION:

*Do not attempt to lift the generator set by the means of the lifting eyes on the engine or generator end. These lifting points are only for the use during the manufacturing process and are designed for lifting of the individual generator set components.*

### WARNING:

*NEVER attempt to lift the fuel tank filled with fuel. Sloshing of the fuel can cause a shift in the balance of the fuel tank, making for a DANGEROUS, unbalanced lifting load. If the generator was shipped on the fuel tank, use the lifting points located on the fuel tank to move the entire generator set into place. DO NOT PLACE FUEL IN THE TANK PRIOR TO LIFTING.*

## INSTALLATION

### WARNING: PERSONAL INJURY:

*PERSONAL INJURY - Before proceeding with the installation, be sure the DSE 7310 MKII is in the "stop" position. Before proceeding with the installation, be sure the Generator MLCB (Main Line Circuit Breaker) is in the 'OFF' position and the unit starting battery is disconnected.*

## GENERAL INFORMATION

This engine-generator set is generally supplied as weather enclosed packages for quick installation on an outdoor concrete pad. They are also available as open skid mounted units for indoor installation in a building or protective enclosure, properly ventilated, supplied by the installer. The factory weather enclosures are acoustical housing intended for outdoor installation only. Factory weather enclosed units are not intended to be used indoors and no support is available to assist in re-engineering finished packaged units.

All versions must be bolted to a solid base for proper operation. A properly designed concrete pad is necessary for stationary operation. A substantial DOT certified trailer is required for mobile applications. Consult a qualified, licensed electrician or contractor to install and wire the gen-set. The installation must comply with all national, state, and local codes.

Before beginning the installation process, recheck the voltage, phase, and amperage rating of the generator set. Be certain it can handle the intended load and are compatible with the intended loads. Plans for installation should be prepared with proper attention to mechanical and electrical engineering detail to assure a satisfactory system installation.

The information in this manual is offered only as a guide to finalizing your installation plans.

### NOTICE:

*For full service switching of the entire load, the ATS must be 'SE' (Service Entrance) rated or must have a properly rated fusible disconnect installed before the ATS to protect the contacts.*

## ENGINE GENERATOR SET MOUNTING

The unit's main frame must be bolted solidly to a solid base. The engine-generator is mounted on channels which are attached with special shock mounts to the main frame. This allows the engine-generator free movement without affecting the base or surrounding equipment.

### WARNING: EQUIPMENT DAMAGE:

*Never mount these engine-generator sets to a wooden base/structure. Over time, the wood will deteriorate and the unit mountings will come loose. These units must be mounted to a steel or concrete base.*

The unit should be mounted to allow ample working room around it. A general rule to follow is to allow 24 inches or more of clearance for maintenance. Follow local codes for clearance from combustible surfaces.

## INSTALLING THE FUEL LINE

### WARNING: FIRE DANGER:

*Connecting rigid fuel line (i.e. steel or copper line) directly to the inlet fuel filter or fuel pump may cause the fuel line to crack during operation creating a serious fire hazard.*

The fuel supply should be as close to the engine as possible. This will reduce the installation cost of fuel runs and minimize line losses. The diesel fuel supply should be no more than 3 feet below the fuel inlet on the pump. If your fuel supply is lower than three feet you may have to install an additional lift pump to bring the fuel up to the mechanical fuel pump on the engine.

The information in this manual is offered to assist you in providing the proper fuel for your engine. However, this information is only provided to inform you of the engine's requirements and assist in making you aware of the decisions you must make. In no case should the instructions or information provided be interpreted to conflict with any local, state, or national codes. If in doubt, always consult your local fire marshal or fuel supplier.

Engine generator sets are properly adjusted before they leave the factory. Connecting a fuel supply with adequate supply volume is critical to reliable operation. Diesel units with optional base mounted fuel tanks are pre-plumbed to the mechanical fuel pump on the engine.

Open skid mounted Diesel units are often supplied with capped inlet and return lines. The use of a sustainable customer supplied flexible fuel line is essential between the engine and fuel supply to provide a vibration break between your fuel supply and the engine.

## LUBRICATION

Before starting the engine, check the oil level in the crankcase. If it is low, refill to the full mark with the proper weight/grade of oil as recommended by the engine manufacturer's maintenance instructions. The necessity of using the correct oil, and keeping the crankcase full, cannot be over emphasized. Failure to use the proper oil and keep the crankcase properly filled will cause excessive engine wear and shorten its useful life.

### DR2014 & DR3014

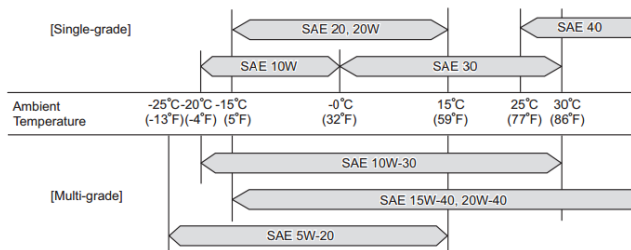

### DR45F4 - DR130F4

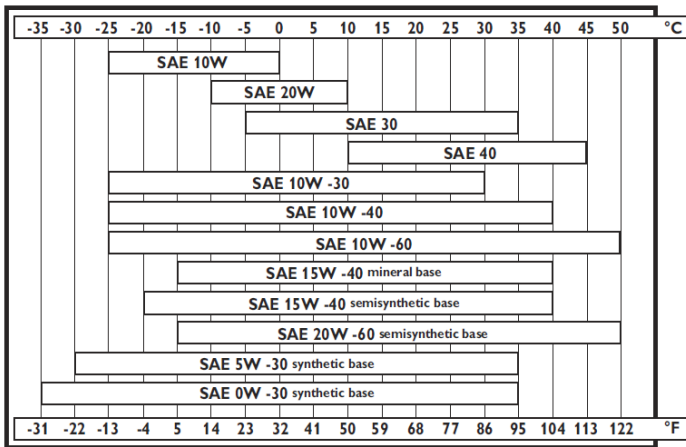

## INSTALLING THE BATTERY

### CAUTION:

In the following battery installation procedure, check to be sure the DSE 7310 MKII is in the "stop" position. This should be your last step before initial start-up.

A customer supplied Group 24/350 CCA battery is required to complete the installation. Installation of the highest CCA rated battery, within the correct BCI group, will increase cold weather starting performance.

### BATTERY REQUIREMENTS

Model	Voltage	BCI Group	Min. CCA Rating
DR2014 - DR65F4	12	24	650
DR90F4 - DR130F4	12	31	900

Installation and servicing of batteries must only be performed or supervised by personnel knowledgeable of batteries and the required precautions. Keep unauthorized personnel away from batteries.

When installing or replacing batteries, use the proper group/size starting battery. The battery should be a maintenance-free lead acid design. Deep cycle batteries will not work for this application.

### CAUTION: PERSONAL DANGER:

**NEVER** dispose a battery in a fire. The battery is capable of exploding.

**DO NOT** open or mutilate the battery. Released electrolyte is known to be harmful to the skin and eyes and to be very toxic.

These engine-generator sets are all NEGATIVE ground. Be very careful not to connect the battery in reverse polarity, as this may short circuit the battery charging system on the engine.

### CAUTION:

A battery presents a risk of electrical shock and high short circuit current. The following precautions must be observed when working with batteries:

1. Remove watches, rings, and other metal objects.
2. Use tools with insulated handles.
3. Check both the battery cable ends and the battery posts to be sure they are free of corrosion.
4. Always connect the battery positive cable first and then connect the battery negative cable. When removing the battery cables from the battery, reverse the procedure, disconnect the negative first and then the positive cable.
5. Be sure all connections are tight and coat the terminals and cable ends with dielectric grease.

### WARNING:

The electrolyte is diluted sulfuric acid that is harmful to the skin and eyes. It is electrically conductive and corrosive. The following precautions must always be taken.

1. Always wear full eye protection and protective clothing.
2. Where electrolyte contacts skin, wash off immediately with water.
3. If electrolyte contacts the eyes, flush thoroughly and immediately with water and seek immediate medical attention.
4. Spilled electrolyte is to be washed down with an acid neutralizing agent. A common practice is to use a solution of one pound of bicarbonate of soda (baking soda) to one gallon of water. The bicarbonate of soda solution is to be added until the evidence of reaction (foaming) has ceased. The resulting liquid is to be flushed with water and the area dried.

### DANGER: EXPLOSIVE FIRE RISK:

1. Never smoke when near batteries.
2. Do not cause a flame or spark in the battery area.
3. Always discharge static electricity from your body before touching batteries by first touching a ground metal surface.

## SERVICING BATTERIES

Batteries used on these units may, over time, lose water. This is especially true if you are using a trickle charger to maintain your battery. Different types of batteries require various types

of maintenance. Refer to the battery manufacturer for specific recommendations.

**NOTE:** Always make sure that a new battery is fully charged before installing it on a generator set. Failure to do so can cause damage to the engine control module in the generator set.

All connections must be clean and tight. Depending on your battery type, check the electrolyte in the battery periodically to be sure it is above the plates. Never allow the battery to remain in a discharged condition.

## CONNECTING BATTERY CHARGER & BLOCK HEATER

A three-stage battery charger is provided standard on this unit. The charger is an Automatic Battery Charger & Maintainer. This charger has three rates of charging. During the first mode, known as Bulk charging, the charging current is limited to 10 Amps at a voltage of up to 14 Volts. The yellow LED will be on constantly during this stage. When the charging rate drops to 2.5 Amps, the charge will enter the ABSORPTION charging mode. During this mode, the yellow LED will be flashing. The charging voltage is held at 14 Volts and the charging rate gradually reduces the amount of current (Amps) flowing to the battery to 100% charged state. The battery can be left on this mode indefinitely. During this mode, the green LED will be on constantly.

This charger is mounted under the customer connection on the control side of the generator and plugged into the receptacle mounted in the AC connection cabinet. The battery charger receptacle is to be powered by a GFCI circuit and installed in accordance to the US National Electric Code. It is suggested that this circuit be fused to 20 Amps.

The block heater on this unit is a 750 watt heater can use the same 20 Amp GFCI fused circuit. This circuit will terminate on the 120 Volt terminal block mount in the customer connection cabinet. The engine blockheater installed on this unit should also be plugged into this receptacle. The block heater is thermostatically controlled when plugged in will maintain the engine coolant temperature between 100 and 120 degrees F.

## MOUNTING THE AUTOMATIC TRANSFER SWITCH

### WARNING: FIRE HAZARD:

All wiring must be done by a licensed electrician, and must conform to the National Electrical Code and comply with all the local codes and regulations. Check with the local authorities before proceeding.

### INSTALLATION NOTES:

Because of many different types of service, feeder and distribution equipment, no specific wiring instructions can be provided. It is recommended that only copper wire be used. In all cases it is essential that while the load is connected to the generator, there can be absolutely no feedback from the generator to the power line or the power line to the generator. When properly installed, the normal ATS Control and safety system will eliminate all paths and feedback.

To wire the automatic transfer switch into existing wiring, first determine OPM-109

which circuits will be on the emergency load circuit. If the entire load is transferred, the transfer switch can be wired directly after the watt-hour meter and the service entrance, providing the service entrance ampere rating is within the transfer switch's rated capability.

If only specific circuits are to be powered under emergency power failure conditions, an additional distribution panel designated "emergency distribution panel" must be installed.

All selected emergency circuits are removed from main distribution panels and installed in the emergency distribution panel. The ATS is then installed between the main panel and the emergency distribution panel. Suggested circuits: freezer, refrigerator, furnace, emergency lights, sump pump, emergency outlet circuits, etc. Total running load must not exceed generator rating.

## A.C. ELECTRICAL CONNECTIONS

**NOTICE: CLASS 1 WIRING METHODS ARE TO BE USED FOR ALL FIELD WIRING CONNECTIONS TO TERMINALS OF A CLASS 2 CIRCUIT**

All wiring must be completed in accordance with the National Electric Code as well as any state and local codes.

You must pay particular attention to wire size requirement for the amperage of service you are dealing with. The table below provides you guidance on wire sizing based on both wire type and amperage. **Wire amperages have been derated for 40° C ambient temperatures operation.**

### WARNING:

Make sure the generator is disconnected from the battery to prevent accidental starting.

Typical arrangements for 20kW to 45kW Circuit Breaker Box.

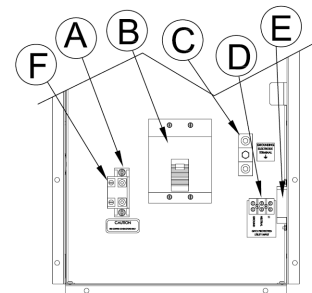

Typical arrangements for 65kW to 135kW Circuit Breaker Box.

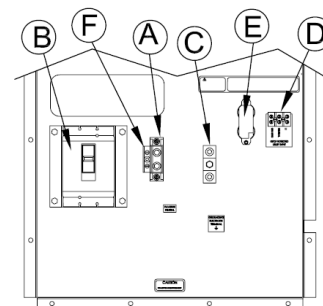

### A. NEUTRAL LUGS:

These lugs are isolated from ground and provided for you to connect your neutral wire from the transfer switch to the generator.

The 1000 Amp terminal block lugs on the 130kW will handle wire sizes #3/0 to 500 MCM and should be torqued to 28 ft. lbs. (Rated for 900 for AL)

The 400 Amp terminal block lugs on the 65 & 95kW will handle wire sizes #1 AWG to 400 MCM and should be torqued to 300 in. lbs.

The 225 Amp terminal block lugs on the 20 to 45kW will handle wire sizes #4 to 300 MCM and should be torqued to 250 in. lbs.

### B. GENERATOR CIRCUIT BREAKER:

This circuit breaker provides overload protection for the generator. Your power feeds from the transfer switch will connect the bottom lugs on the circuit breaker. The generator power feeds have already been wired into the upper lugs.

Please refer to the circuit breaker installed on your unit for breaker lug capacities and proper torque specifications.

To select the proper conductor size between the generator and the ATS, first look your model up in Table 1 of Appendix "A" for your generator amperage, found further in this manual. Then refer to Appendix "2" for guidance on wire sizing based on both wire type and amperage.

For additional information on wire sizes, refer to table 310-16 of the National Electrical Code ANSI/NFPA 70.

### C. GROUND LUG:

These ground lugs are bonded to ground and are provided for you to connect your ground wire from the transfer switch to. The lugs will accommodate #10 AWG to 2/0 AWG and should be torqued to 200 in. lbs.

### D: 120V GFCI CIRCUIT TERMINAL BLOCK:

These terminals are rated for 85 Amps and will handle wire sizes #4 AWG to 18AWG. They should be torqued to 16 in. lbs. This circuit must be fed from a fused circuit in the distribution panel and provides power for the blockheater and the battery charger.

### E: 120V/20 AMP DUPLEX RECEPTACLE:

This convenience receptacle is used to power both battery charge and blockheater. This circuit must be fed from a GFCI fused circuit in the distribution panel.

### F: NEUTRAL TO GROUND LEAD LUG:

This lug is provided on the neutral terminal block to allow you to run a neutral to ground lead if you are using the generator in a stand alone application. This would be an application where there is not a distribution panel and no other ground to neutral bond in the wiring system. If a grounding wire is attached here, remove the floating neutral label in the panel. This will not be used when you are wiring a generator and transfer switch into an existing power system.

### WARNING:

*A mainline circuit breaker has been provided inside the generator housing. During all wiring installations, make sure the breaker is in the OFF position and the generator operating switch is in the OFF position.*

### WARNING: EQUIPMENT DAMAGE:

*When installing a three-phase 240 Volt system, be sure you know which lead is the high voltage "wild" leg (208 Volt line to neutral). The generator normally carries the high voltage on the G2 lead.*

All wires should be installed in rigid or flexible conduit (knockouts are provided in the control box).

## GROUNDING

A grounding lug has been provided on the engine generator set and the generator set must be properly grounded to good earth ground. Generally an 8 foot copper rod driven into the earth will provide a proper earth ground.

## D.C. ELECTRICAL CONNECTIONS

All DC connections are completed on the terminal strip just below the engine control. All DC connection must be separate conduit. You cannot mix AC and DC leads at the same conduit.

### CONNECTION BOX TERMINALS

Wire size requirements for each of the connections may vary but terminal lugs should be used for all connections. Torque spec for terminal lugs is 9 in. lbs.

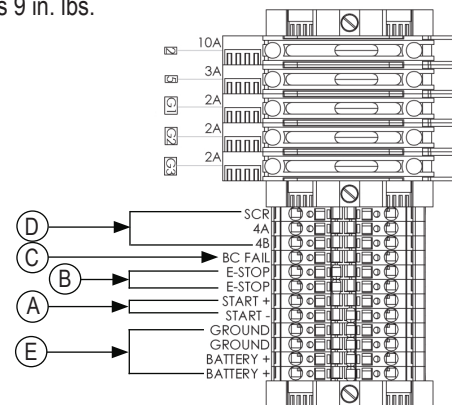

A - Customer Remote Start CONNECTIONS TERMINALS. The two remote start leads from the Automatic Transfer Switch are connected to the two terminals marked Remote Start & Remote Start. The wire in terminal labeled #1 is Battery Negative/Ground and the wire in the terminal labeled #23 is your Remote Start lead. Closing these two leads together will signal the DSE 7310 MKII to go into an autostart mode and start up the engine generator.

Depending on the distance, 14 to 16 gauge stranded wire should be used. It is suggested that these wires be labeled S1 and S23.

Note: Any relay closure can be used to start and stop this generator. As long as the contact stays closed the engine generator set will continue to run. Once the relay is opened the unit will shut down and remain in the standby mode until the remote start relay is closed again.

B - ESTOP- & ESTOP+. Remote Emergency Stop terminals. These two terminals are shipped with a jumper installed. If your application requires the installation of a Remote Emergency Stop switch, remove the jumper and wire your switch to these terminals. This unit will not start and run without either the jumper installed or a remote N/C switch installed..

C - Battery Charger Failure. Battery charger failure relay input from remote battery charger to DSE7310 controller.

D - Remote Display Panel Interface Terminals. These interface terminals are pre-wired to allow for the connection of a remote display. This display allows for the remote annunciation of alarms at a location such as a nurses station or a control room.

E - Battery Positive and Ground ( battery negative). These terminals are dedicated for any accessory that will be installed. There is a maximum of 7 Amps combined.

## DC INTERCONNECTIONS TO THE ATS

### WARNING:

Be sure Engine/Generator is in the OFF position before you make any DC interconnections.

### CAUTION:

Never run the AC and DC wiring in the same conduit.

## ASCO 185 UL SWITCH

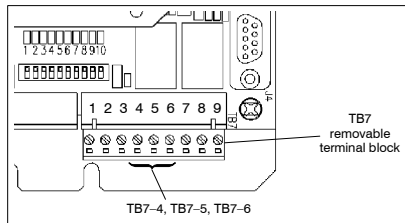

TB7 Generator starting contact terminals

Table A. Generator Start Connections

When the Utility fails	Terminals on Controller
contact closes	TB7-4 and TB7-5
contact opens	TB7-5 and TB7-6

## ASCO 300 UL SWITCH

Your DC connection points in the ASCO 300 ATS terminals “14” and “15”. Depending on the size of the switch, they are located in different locations.

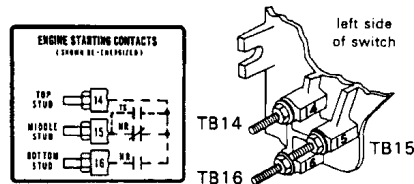

Engine starting contact label and location for 30 - 200 amp switches.

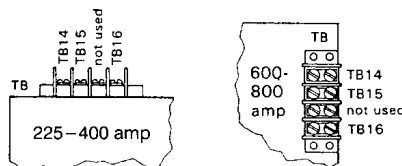

# STARTING PROCEDURE

## CONTROL LAYOUT

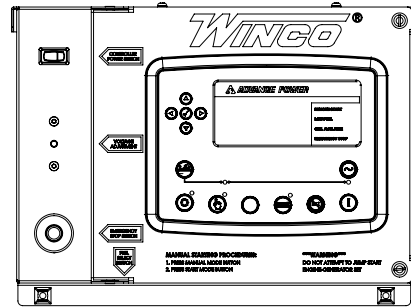

	STOP/RESET - This button places the module into its Stop/Reset mode. This will clear any alarm conditions for which the triggering criteria have been removed. The fuel supply de-energizes and the engine comes to a standstill. Should a remote start signal be present while operating in this mode, a remote start WILL NOT occur.
	MANUAL MODE - This button places the module into its Manual Mode. Once in Manual Mode, the model responds to the Start button to start the generator and run it off load.
	START - Pressing this button from STOP/RESET will start the engine and run the load.
	AUTO MODE - This button places the module into its Auto Mode. This mode allows the module to control the function of the generator automatically.
	ALARM/LAMP TEST - This button silences the audible alarm in the controller, de-activates the Audible Alarm output (if configured) and illuminates all of the LEDs on the module's face as a lamp test function.
	MENU NAVIGATION - Used for navigating the instrumentation, event log, and configuration screens.

## PROTECTIONS

When an alarm is present, the common alarm LED if configures will illuminate. The LCD display will show an icon to indicate the failure.

## WARNINGS

Warnings are non-critical alarm conditions and do not affect the operation of the generator system, they serve to draw the operator's attention to an undesirable condition. Warning alarms are self-resetting when the fault condition is removed. The icon will appear steady in the display.

## SHUTDOWN

Shutdowns are critical alarm conditions that stop the engine and draw the operator's attention to an undesirable condition. Shutdown alarms are latching. The fault must be removed and the STOP/RESET button pressed to reset the module. The icon will be flashing in the display.

## INITIAL START UP

### WARNING: EQUIPMENT DAMAGE:

Before attempting to start this unit, complete your pre-start checklist and ensure the generator mainline circuit breaker is in the proper

position prior to starting. Starting this unit without it properly connected can cause serious personal injury or equipment damage.

DO NOT jump start these engine-generator sets. Starting these units on a low battery or jump starting them will cause damage to the engine control module.

Use the following check list to verify correct installation before starting the engine.

- Engine oil. Fill as required with proper grade/qty.
- Engine coolant. Fill as required with proper mixture.
- Unit mounting base properly bolted down.
- Clearance for service and maintenance on all sides.
- Proper fuel line material and size.
- All fuel line connections tight.
- Battery connections clean and tight
- Battery fully charged.
- All AC and DC wiring installed and properly protected.
- Compressor oil. Fill as required with proper grade/qty.

After completing the previous checklist, the engine-generator set is ready for initial start-up.

## MANUAL MODE

1. Press and release the MANUAL MODE button. The small LED light next to it should come on.

**Note:** There is no start delay in this mode of operation.

2. Press and release the green START ENGINE button. The DSE 7310 MKII will send two signals to the engine. The first signal wire #21 will engage the fuel solenoid, the second wire, #22, will engage the starter on the engine. At this point the DSE 7310 MKII will start the cranking cycle (10 seconds on and 10 seconds off).

**Note:** Wire #93 is energized to turn on the glow plugs for 15 seconds first and then the starter and fuel solenoid are engaged.

If the engine fails to start during this cranking period, the starter motor is disengaged and goes into a rest mode after which a second attempt is made to start the engine. Should this sequence continue through 3 cranking cycles the start sequence will be stopped and the display will show 'FAILED TO START'.

3. During manual operation, the load will not normally be applied to the generator. But caution must be used, if the line power should fail or be turned off the transfer switch during manual operation the load may be applied to the generator.

With the engine running smoothly check the no load voltage and frequency on the digital display. The voltage should be 208/240/480 AC depending on which model you have and a frequency of 59.5 to 60.5 hertz (Hz).

If you have the proper voltage at the generator the next step is to check the voltage at the generator terminals in the Automatic Transfer Switch. The voltage between the G1 and the G3 terminals should be the same as it was on the generator front panel. The voltage should also be checked between the hot terminals (G1 and G3) and the G-N to

be certain of a balanced voltage output and a solid neutral connection. The voltage between G1 and G-N should be about 120 volts AC (277 on 480 units). The same approximate voltage should be found between terminals G3 and G-N (120 volts AC).

On three phase panels the G2 voltage level should also be checked. ON 240 VOLT (DELTA) SYSTEMS BE SURE YOU KNOW WHERE THE HIGH VOLTAGE "WILD" LEG IS. IT MUST BE IN THE SAME LOCATION ON THE LINE SIDE AS IT IS ON THE GENERATOR SIDE. (i.e. if it's on L-3 on the line side it must be on G-3 on the generator side. **Also on three phase systems make sure that the rotation is the same on the generator as it is on your line power. Failure to insure proper rotation will cause three phase motors to spin backwards possibly damaging them.**

### NOTICE:

*If for any reason during the check out procedure the voltage and frequency are not correct, depress the STOP/RESET button and correct the trouble before proceeding.*

4. Stopping - There are two ways to stop the unit when it is in the manual mode. Pressing the STOP/RESET button will stop the unit immediately. Pressing the AUTO mode button will stop the unit but only after the cool down timers have timed out and there is no remote start signal being sent to the unit.

## AUTO MODE

To activate the automatic start mode you will just need to depress the AUTO button, the LED indicator beside the button confirms that the unit is in automatic mode.

To test the Automatic Transfer Switch, follow the instruction on the operator's manual that came with the transfer switch. If you get a fault during the initial start up or prior to start up, it is most likely a false warning light. Simply reset the ATS start over.

Once you have completed testing of the ATS, be sure you ALWAYS leave the system in the standby mode, unless servicing the unit. For standby operation, press the AUTO button on the front of the control. The green light should light up next to the AUTO button.

NOTE: For setting the exerciser circuit, for all ATS, see the operator's manual shipped with the ATS.

# MAINTENANCE SCHEDULE

## ISUZU

SERVICE	INTERVALS
Check Engine Oil Level	Daily
Check Coolant Level and for Leakage	Daily
Check Air Filter	Daily
Check Electrolyte Level in Battery and Clean Terminals	90 Days
Drain Water from Fuel Pre-Filter	Daily
Check Belts and Belt Tension	Daily
Check Preheating Operation	Daily
Change Oil - Initial - After Initial	50 Hours 250 Hours
Change Oil Filters - Initial - After Initial	50 Hours 500 Hours
Change Fuel Filters	500 Hours
Check Exhaust System for Damage	180 Days
Clean Fuel Tank	180 Days
Change Air Filter (depending on conditions)	600 Hours
Check Valve Clearance	1000 Hours
Clean Crankcase Ventilation Valve	1500 Hours
Change Coolant/Clean System	1000 Hours

\* There are additional maintenance items and explanations in the engine operator's manual. Read thoroughly before operating this unit.

## FIAT

SERVICE	INTERVALS
Check Engine Oil Level	Daily
Check Coolant Level and for Leakage	Daily
Check Air Filter	Daily
Check Electrolyte Level in Battery and Clean Terminals	6 Months
Drain Water from Fuel Pre-Filter	150 Hours
Check Belts and Belt Tension	300 Hours
Check Oil Vapor Filter	300 Hours
Change Oil	600 Hours
Change Oil Filters	600 Hours
Change Fuel Filters	600 Hours
Change Fuel Prefilter	600 Hours
Check Exhaust System for Damage	6 Months
Clean Fuel Tank	6 Months
Change Auxiliary Member Belt	1200 Hours
Change Air Filter (depending on conditions)	1200 Hours
Change Coolant	1200 Hours
Change Oil Vapor Filter	2 Years
Clean Turbocharger	1200 Hours
Adjust Play in Valve-Rocker Arms and Pump-Rocker Arms	1200 Hours

\* There are additional maintenance items and explanations in the engine operator's manual. Read thoroughly before operating this unit.

# TROUBLESHOOTING TABLE

Problem	Possible Causes
Unit will not crank when power fails	Digital genset not in AUTO Transfer control switch not in AUTOMATIC position Incorrect wiring between ATS and genset Defective control relay in ATS Fuse(s) blown in the DSE 7310 MKII Defective DSE 7310 MKII Loose or dirty battery terminals Defective starter Defective start solenoid Low/dead battery
Engine won't crank	Low/dead battery Blown DC fuses Defective DSE 7310 MKII Defective key switch Loose or dirty battery terminals Defective starter Defective start solenoid Locked up engine genset Defective engine harness Improper battery voltage to start solenoid, fuel pump, or fuel solenoid
Engine cranks but will not start	Improper fuel delivery to the unit Fuel supply shut off Fuel tank empty Air in the fuel system Engine fuel solenoid has not opened Defective fuel pump Defective fuel solenoid Defective engine harness Improper battery voltage to fuel pump or fuel solenoid
Engine starts, then stops and alarm light comes on	Engine oil pressure is low Engine has high water temperature Engine has overspeed Engine has gone into overcrank No output from AC generator Loss of speed signal Loss of run signal
Engine will not come up to speed after it starts	Insufficient fuel volume getting to the unit 1. Too small of fuel line 2. Fuel racks not open properly Governor is defective AC short in generator components
ATS will not transfer to Emergency Supply (generator)	No AC generator output Defective ATS control board. See ATS manual Circuit breaker open or defective
ATS will not re-transfer to normal power	Proper power line not available at line terminals in ATS panel Defective ATS control board. See ATS manual
No AC output from generator	Defective diode Defective voltage regulator Defective rotor Defective stator Defective exciter rotor Defective exciter stator AC short in the output leads Defective/open generator output breaker Wiring error

# VOLTAGE REGULATOR WIRING

## SX460 Automatic Voltage Regulator

The following is a list of connections on the AVR. These have been factory set and other than voltage adjustment, should never be changed.

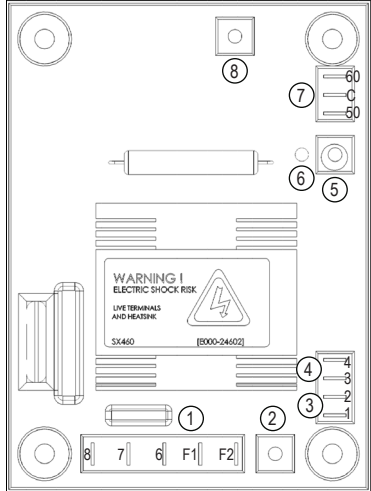

1. Generator AC sensing connection (6,7, & 8)  
Field voltage DC (F1 & F2)
2. Voltage adjustment
3. External voltage treatment rheostat.  
No external rheostat - link 1 & 2  
With external rheostat - 1 & 2 unlinked, connect external rheostat leads to 1 & 2
4. AVR input selection  
High voltage 208/240/277 - no link between 3 & 4  
Low voltage 120 - link 3 & 4
5. Under Frequency Roll Off adjustment
6. Under Frequency Roll Off indication light
7. Frequency selection:  
50 Hz operation - link C to 50  
60 Hz operation - link C to 60
8. Stability control

## WIRING SIZE TABLE

The table below is based on Table 310.15 (B) (16) un the National Electric Code 2014 edition. Allowable ampacities of insulated conductors rated 0 through 2000V, 75°C through 90°C. Not more than three current-carrying conductors in Raceway, Cable, or Earth (direct buried). Adjust for 40°C (104°F) ambient temperature.

Copper 75°C	Copper 90°C		Aluminum Copper Clad Aluminum 75°C	Aluminum Copper Clad Aluminum 90°
Wire Type: RHW, THHW, THW, THWN, XHHW, USE, ZW	Wire Type: TBS, SA, SIS, FEP, FEPB, MI, RHH, RHW-2, THHN, THHW, THW-2, XHH, XHHW, XHHW-2, ZW-2	SIZE AWG OR KCMIL	Wire Type: RHW, THHW, THW, THWN, XHHW, USE	Wire Type: TBS, SA, SIS, THHN, THW-2, THWN-2, RHH, RHW-2, USE-2, XHH, XHHW, XHHW-2, ZW-2
44	50	8	35	41
57	68	6	44	55
75	86	4	57	68
88	100	3	66	77
101	118	2	79	91
114	137	1	88	105
132	155	1/0	106	123
154	177	2/0	119	137
176	205	3/0	136	159
202	237	4/0	158	187
224	264	250	180	209
251	291	300	202	232
273	319	350	220	255
295	346	400	238	278
334	391	500	273	319
370	432	600	299	350
405	473	700	330	382
418	487	750	339	396
431	505	800	348	410
458	532	900	374	437
480	560	1000	392	455
519	605	1250	427	496
550	642	1500	458	532
572	669	1750	480	560
585	683	2000	493	573

For additional information, see table 310.15 of the National Electric Code.



# ENGINE HARNESS SCHEMATIC

## DR20

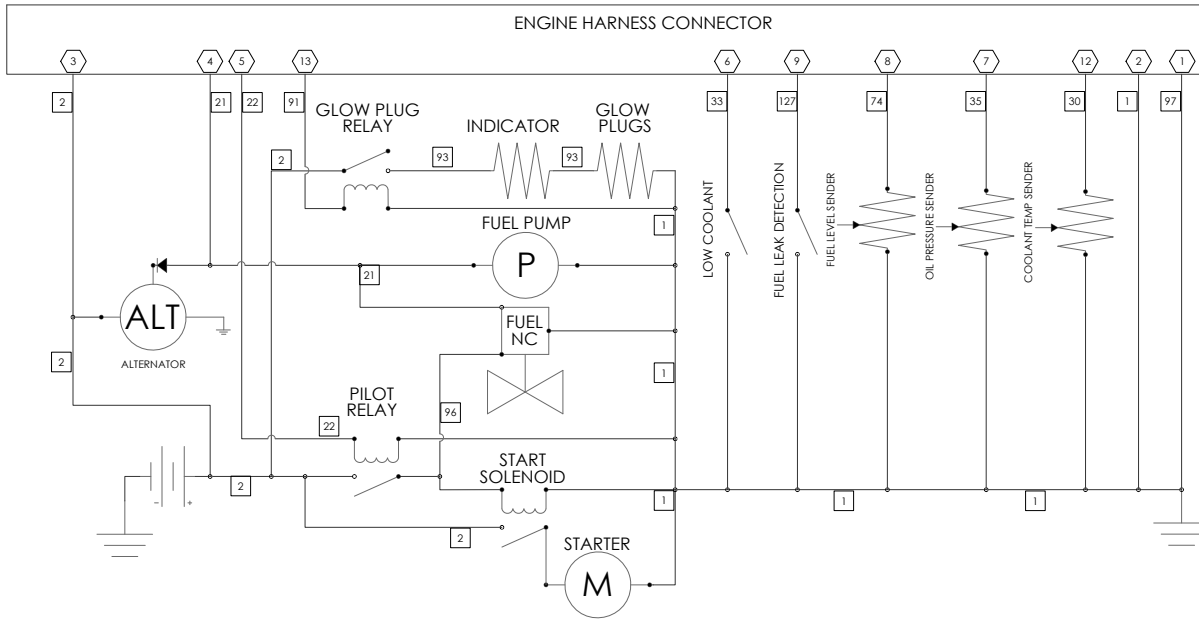

NOTE:

SOME MODELS COME EQUIPPED WITH FUEL LEVEL, OIL PRESSURE AND COOLANT TEMPERATURE SWITCHES. SENDER UNITS PICTURED.

FUEL AND LOW COOLANT MONITORING FEATURES ARE OPTIONAL.

## DR45/DR65

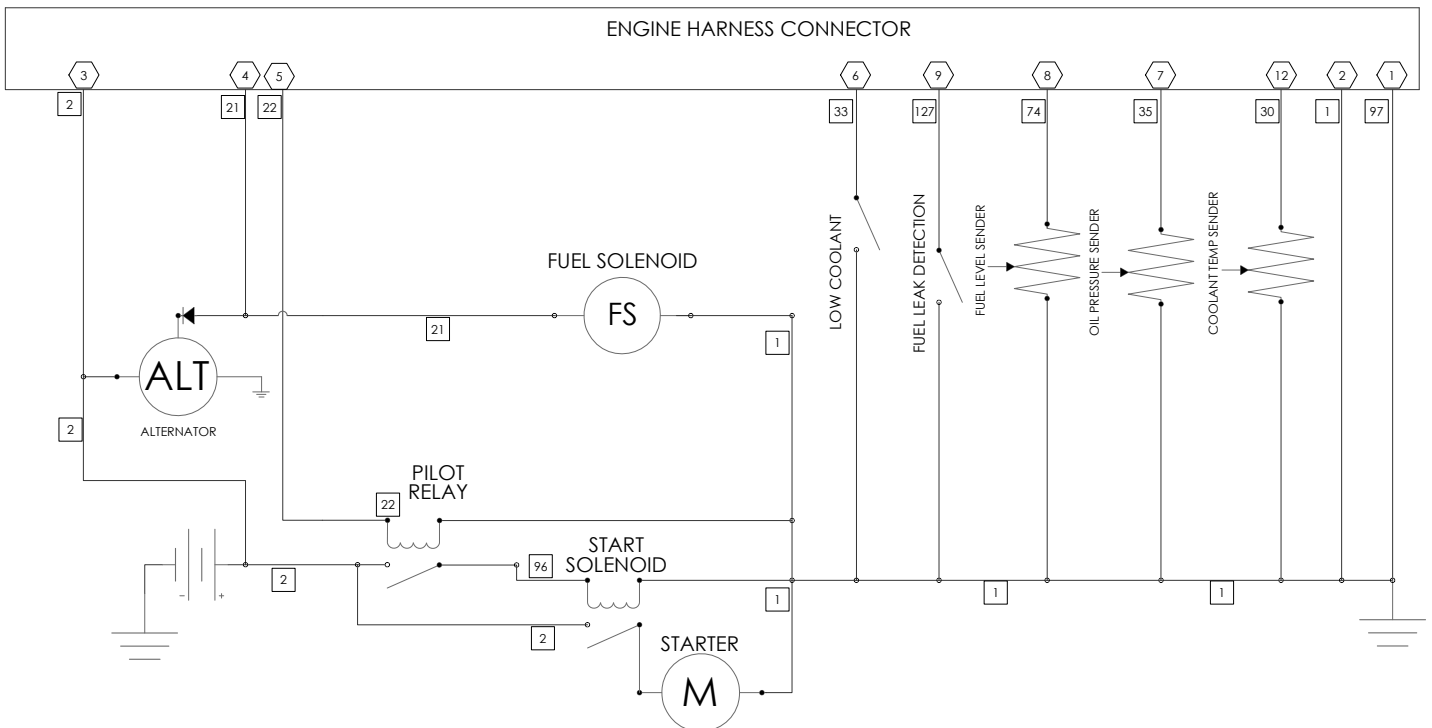

# DSE 7310 MKII WIRING DIAGRAM

DR20 - DR130

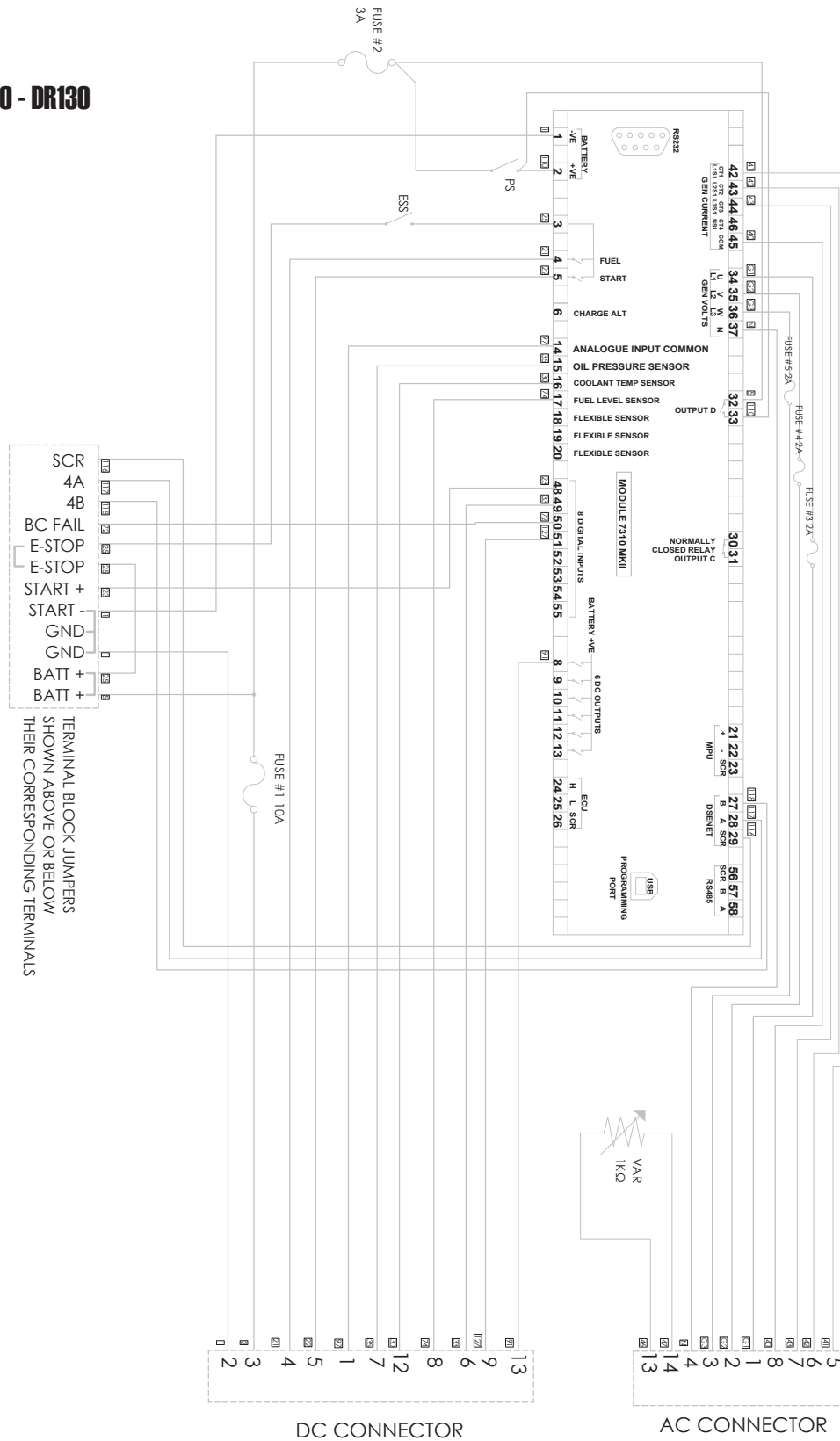

# THREE PHASE AC WIRE HIGH AND LOW WYE

## THREE PHASE - HIGH WYE 277/480V

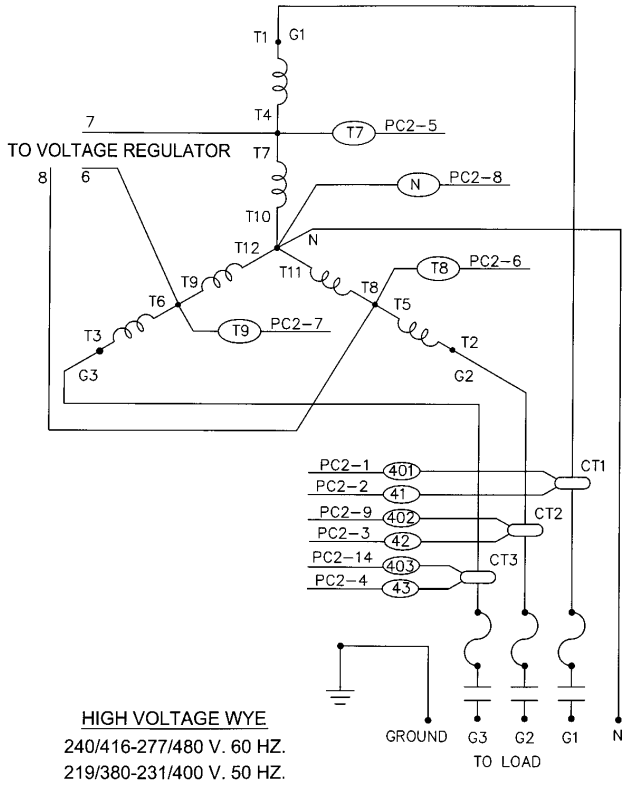

## THREE PHASE - LOW WYE 120/208V

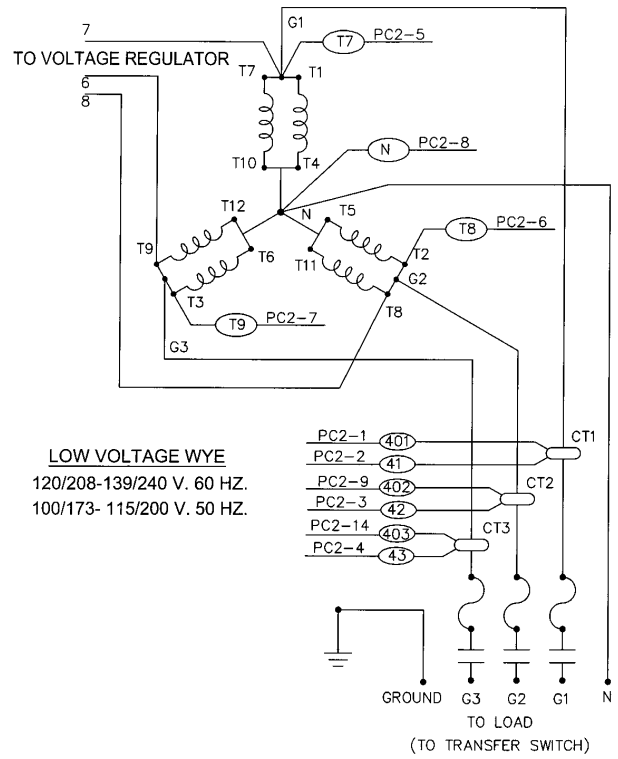

# THREE PHASE WIRING - DELTA

## THREE PHASE DELTA 120/240V

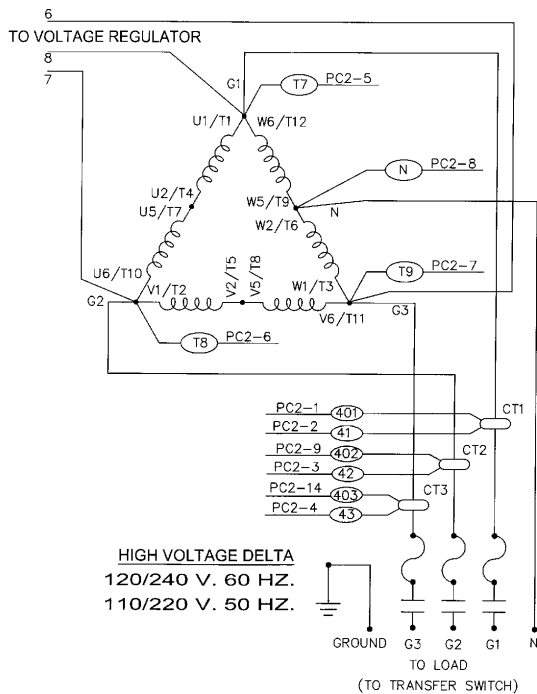

# SINGLE PHASE AC WIRING - 4 LEAD

## SINGLE PHASE 120/240V

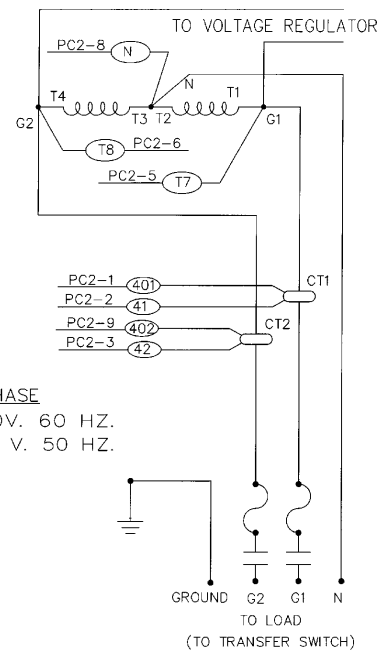



## **12 MONTH LIMITED WARRANTY**

WINCO, Incorporated warrants to the original purchaser for 12 months or 1000 hours which ever occurs first, that goods manufactured or supplied by it will be free from defects in workmanship and material, provided such goods are installed, operated and maintained in accordance with WINCO written instructions.

WINCO's sole liability, and Purchaser's sole remedy for a failure under this warranty, shall be limited to the repair of the product. At WINCO's option, material found to be defective in material or workmanship under normal use and service will be repaired or replaced. For warranty service, return the product within 12 months or 1000 hours which ever occurs first from the date of purchase, transportation charges prepaid, to your nearest WINCO Authorized Service Center or to WINCO, Inc. at Le Center Minnesota.

THERE IS NO OTHER EXPRESS WARRANTY.

To the extent permitted by law, any and all warranties, including those of merchantability and fitness for a particular purpose, are limited to 12 months or 1000 hours which ever occurs first, from date of purchase. In no event is WINCO liable for incidental or consequential damages.

Note: Some states do not allow limitation on the duration of implied warranty and some states do not allow the exclusion or limitation of incidental or consequential damages, so the above limitations may not apply in every instance. This warranty gives you specific legal rights which may vary from state to state.

WINCO reserves the right to change or improve its products without incurring any obligations to make such changes or improvement on products purchased previously.

### **EXCLUSIONS:**

WINCO does not warrant Engines. Engines are covered exclusively by the warranties of their respective manufacturers, see enclosed warranties.

WINCO does not warrant Component Parts that are warranted by their respective manufacturers.

WINCO does not warrant modifications or alterations which were not made by WINCO, Inc.

WINCO does not warrant products which have been subjected to misuse and/or negligence or have been involved in an accident.

This warranty does not include travel time, mileage, or labor for removal or re-installation of WINCO product from its application.