

## Features

### Honda GX340 Engine

You expect the best; you get the best. The Honda GX340 engine has more power, lower fuel consumption, and lower emissions than previous versions.

### Automatic Voltage Regulator

This generator will automatically regulate voltage at +/- 1% and is safe for sensitive electrical equipment.

### Powder Coat Paint

For an incredibly durable finish.

### Sturdy Wrap-Around Welded Tubular Cradle

We use sturdy 14 gauge steel.

### 7 Gallon Fuel Tank

The EPA approved steel fuel tank design eliminates hydrocarbon emissions.

### Premium Circuit Breakers

Providing clear and instant identification of a tripped circuit.

### Conserv-R

Our automatic idle control saves fuel, reduces noise, and preserves engine life.

### 100% Load Tested

You won't find statistical sampling here. We load test every generator before it leaves our facility.

## INDUSTRIAL

**6,000 Surge Watts**  
**5,500 Continuous Watts**

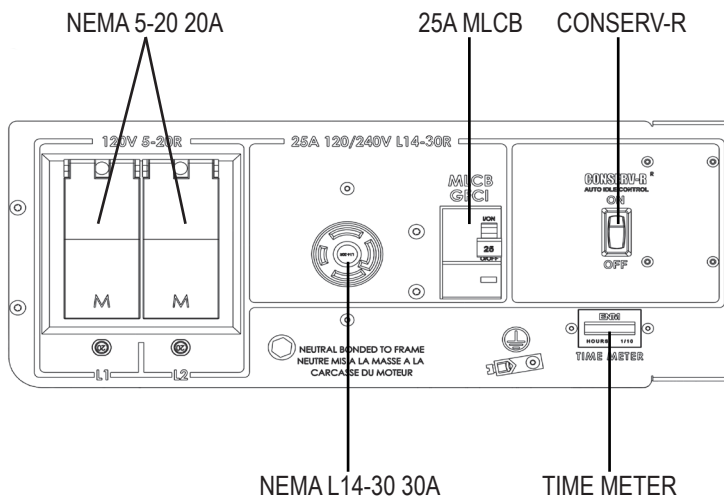

## Optional Accessories

### Two Wheel, Flat-Free Dolly Kit

Portability is important to get your generator where it needs to be.

### Generator Cover

When your generator is not in use, you will want to keep it dust and debris free.

### Plug-In Line Voltage Monitor

For when you want to verify the voltage output.

### 30 Amp (NEMA L14-30P) Plug

You supply the cord you need. We provide the plug.

### Maintenance Kit

Keep the engine at its peak performance to ensure the generator will be ready when needed most.

## GENERATOR

SURGE WATTS	6,000
RUNNING WATTS	5,500
RUNNING AMPS @ 120 VAC	45.8
RUNNING AMPS @ 240 VAC	22.9
VOLTAGE REGULATION	AVR +/-1%
FREQUENCY REGULATION	+/-3%
MAIN CIRCUIT BREAKER	25 AMP, 240V (GFCI)
BRUSHES	YES
BONDED NEUTRAL	YES
120 VOLT RECEPTACLES	(2) NEMA 5-20 20A (GFCI)
120/240 VOLT RECEPTACLES	(1) NEMA L14-30 30A (GFCI)
GENERATOR WARRANTY <sup>(1)</sup>	3 YRS COMMERCIAL

NOTES: (1) For generator warranty information contact your local WINCO service center.

## GENSET

MOTOR STARTING (CODE G) <sup>(1)</sup>	3 HP
SOUND DATA <sup>(2)</sup>	
NO LOAD	79
FULL LOAD	84
LIFTING EYE <sup>(3)</sup>	YES
2-WHEEL DOLLY KIT	OPTIONAL
PROTECTIVE ROLL FRAME	14 GAUGE STEEL
EPA APPROVED	YES
CARB APPROVED	YES
CSA APPROVED	NO
UNIT WARRANTY <sup>(4)</sup>	3 YRS COMMERCIAL

NOTES: (1) Code G capacitor start motor. (2) All measurements are in db(a). Tested at 7 meters (23 ft.). (3) Lifting eye ships loose. (4) For more generator warranty information contact your local WINCO dealer.

## ENGINE

ENGINE BRAND	HONDA
ENGINE MODEL	GX340
ENGINE STARTER	RECOIL/ELECTRIC
ENGINE SPEED	3600 RPM
ENGINE CYLINDERS	SINGLE
DISPLACEMENT/TYPE	389 CC / OHV
LOW OIL PROTECTION	STANDARD
RECOMMENDED OIL <sup>(1)</sup>	10W-30
OIL CAPACITY	1.16 QT
FUEL TANK	7 GAL
FUEL GAUGE	YES
FULL LOAD RUN TIME	8.1 HOURS
TIME METER	YES
BATTERY SIZE <sup>(2)</sup>	BCI 20 OR 24HL 300CCA
ENGINE WARRANTY <sup>(3)</sup>	3 YRS COMMERCIAL

NOTES: (1) The recommended oil is for normal applications. See operator's manual for the recommended oil for your needs. (2) Battery not included (3) Contact your local Honda service center for engine warranty assistance.

## DIMENSIONS

DIMENSIONS	34.25" x 24.625" x 23.4"
NET WEIGHT	212 LBS

NOTES: Dimensions are L x W x H. Add 3" height if lifting eye is installed. Add 6" height if dolly kit is installed.

## SHIPPING

SHIPPING DIMENSIONS	35" x 25" x 24"
SHIP WEIGHT	226 LBS
FREIGHT CLASS	70

NOTES: Dimensions are L x W x H.

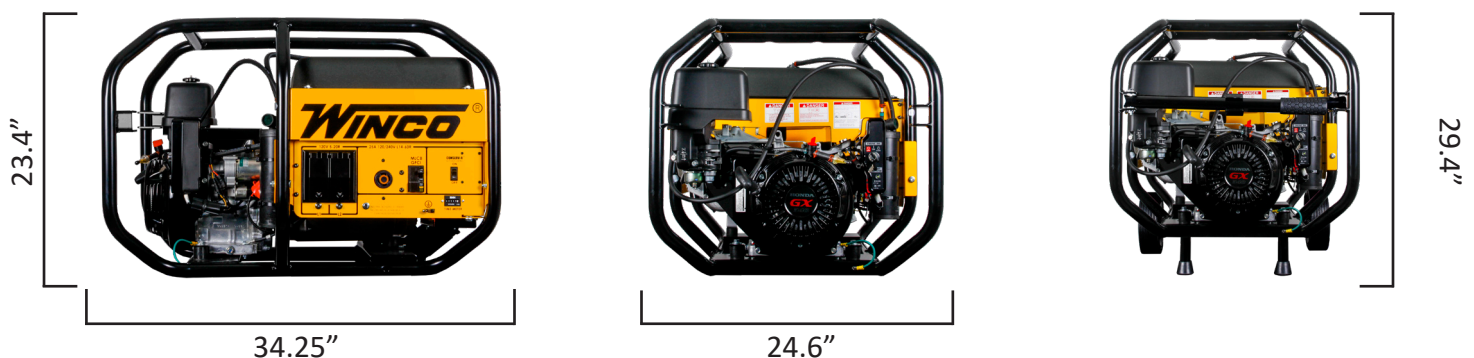

Specifications are subject to change without notice.